

| Nr / No | Ant / Pcs | Ändring / Change | Datum / Date | Inf |
|---------|-----------|---|--------------|-----|
| 1 | - | Updated according to same specification as 5/6 depths | 160311 | PA |
| 2 | - | 3817-3 was 3817-2 | 161028 | PA |
| 3 | - | 3811-3 was 3811-2 | 171012 | PA |

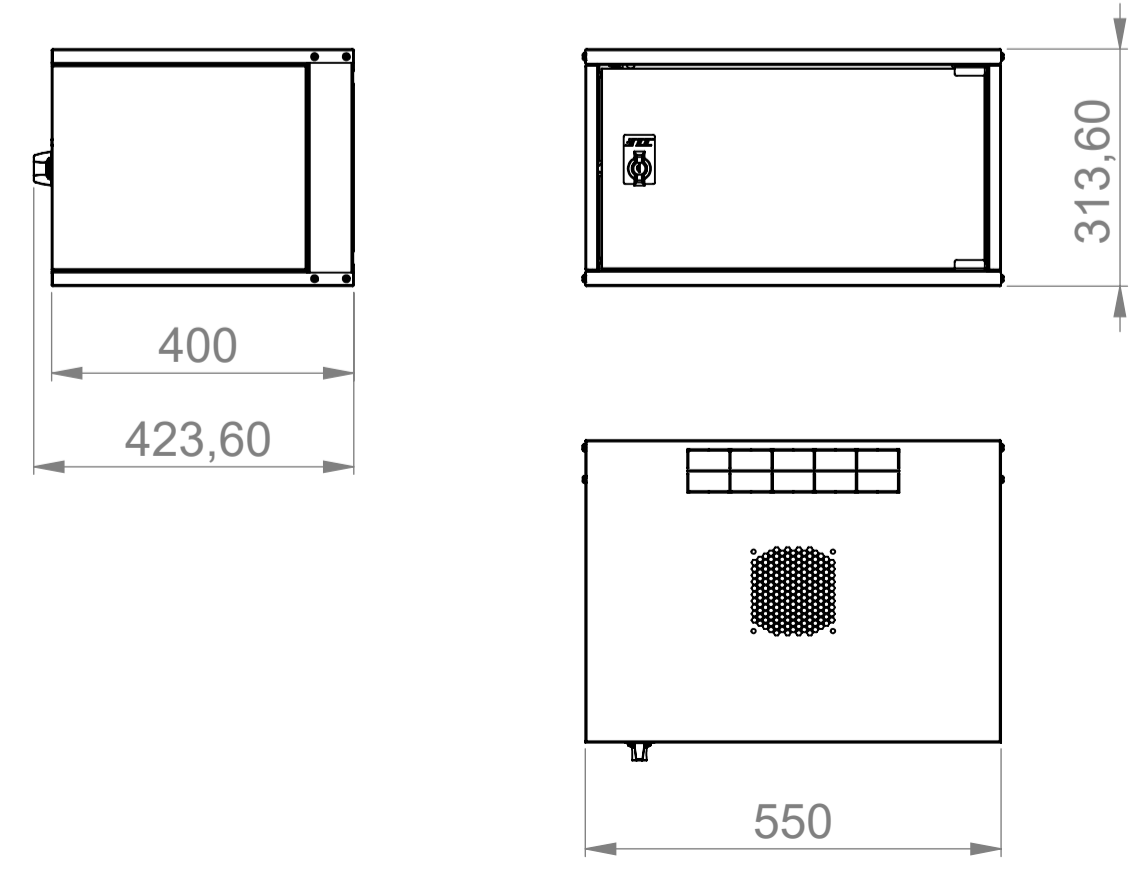
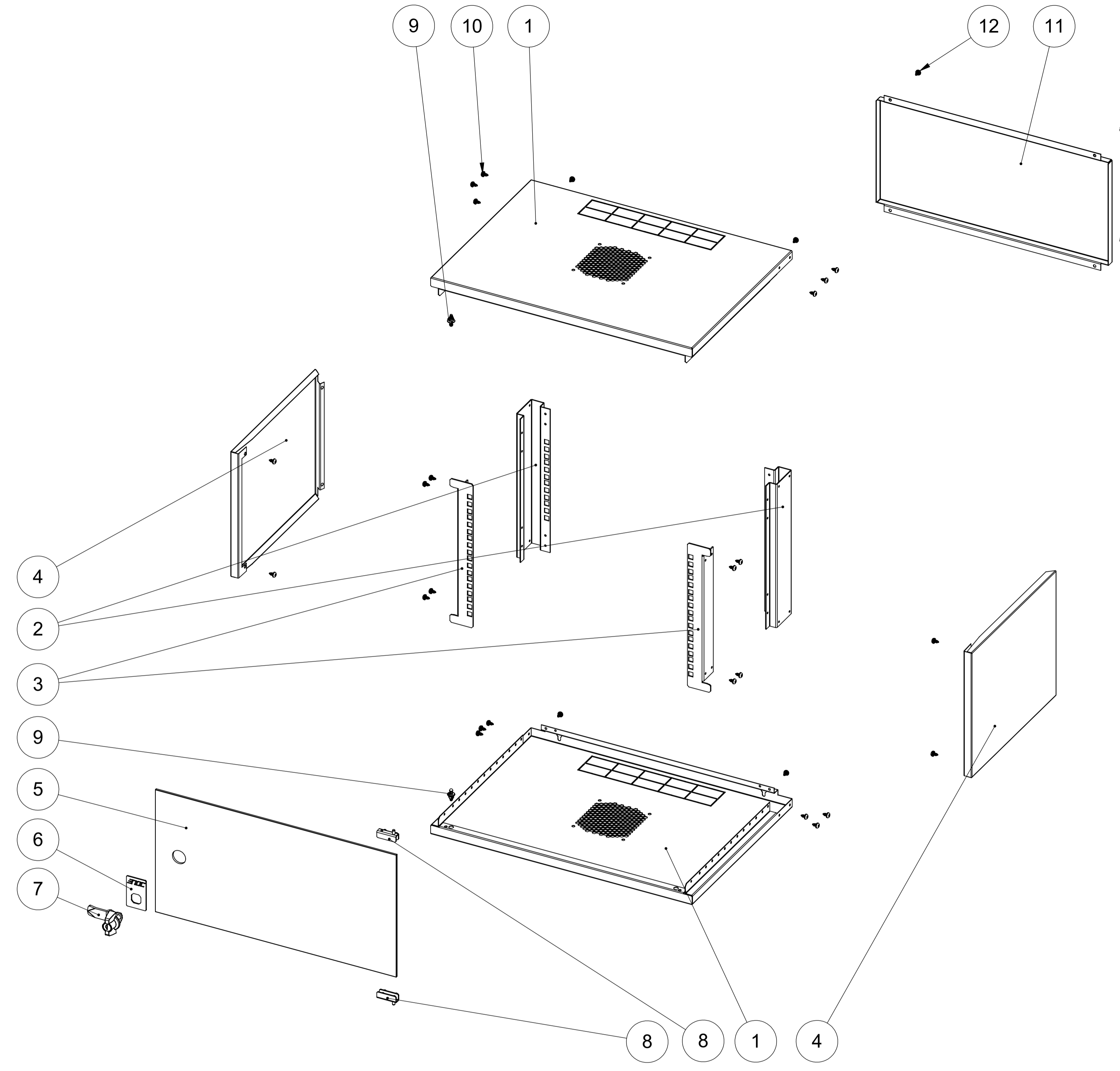
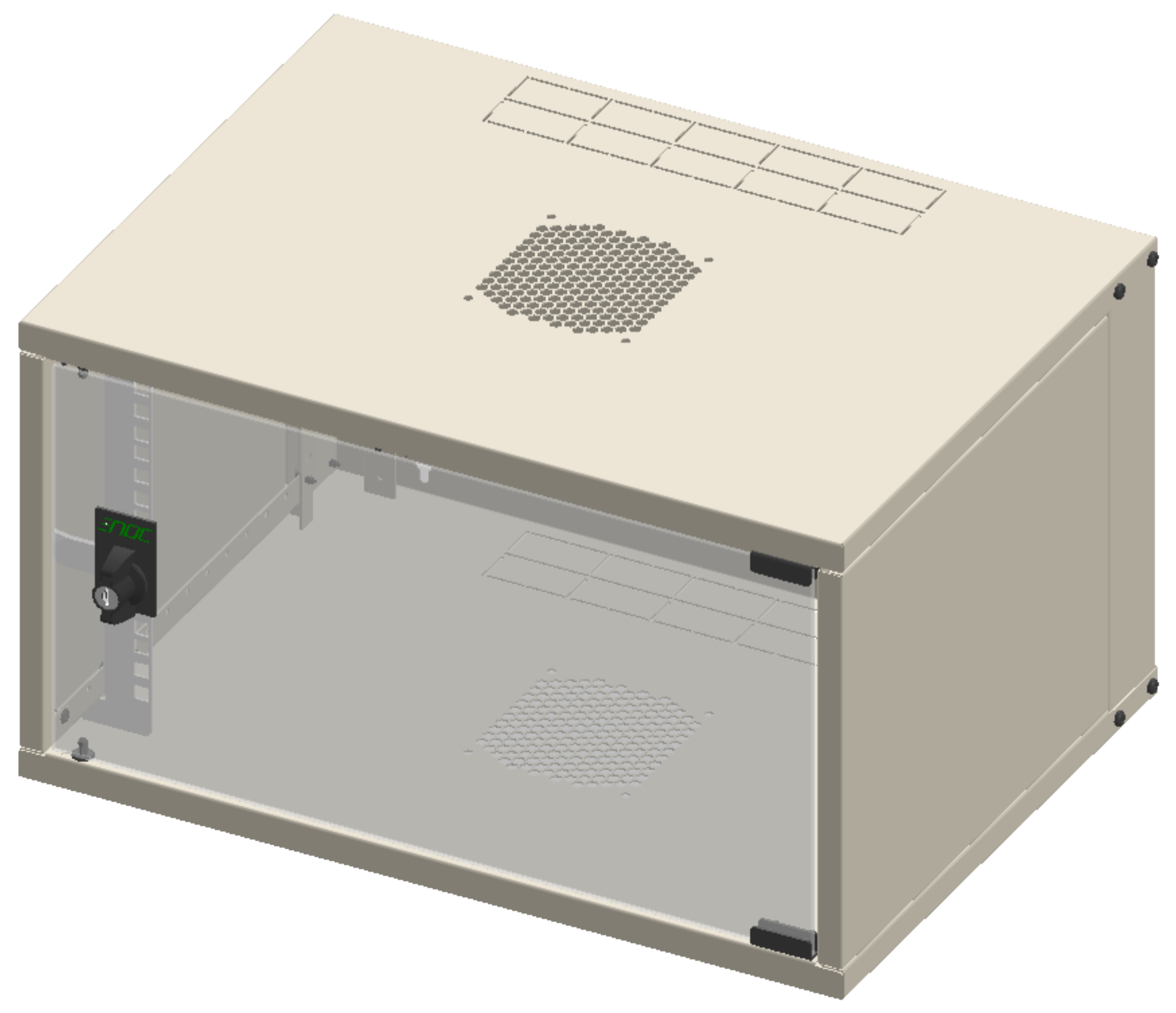
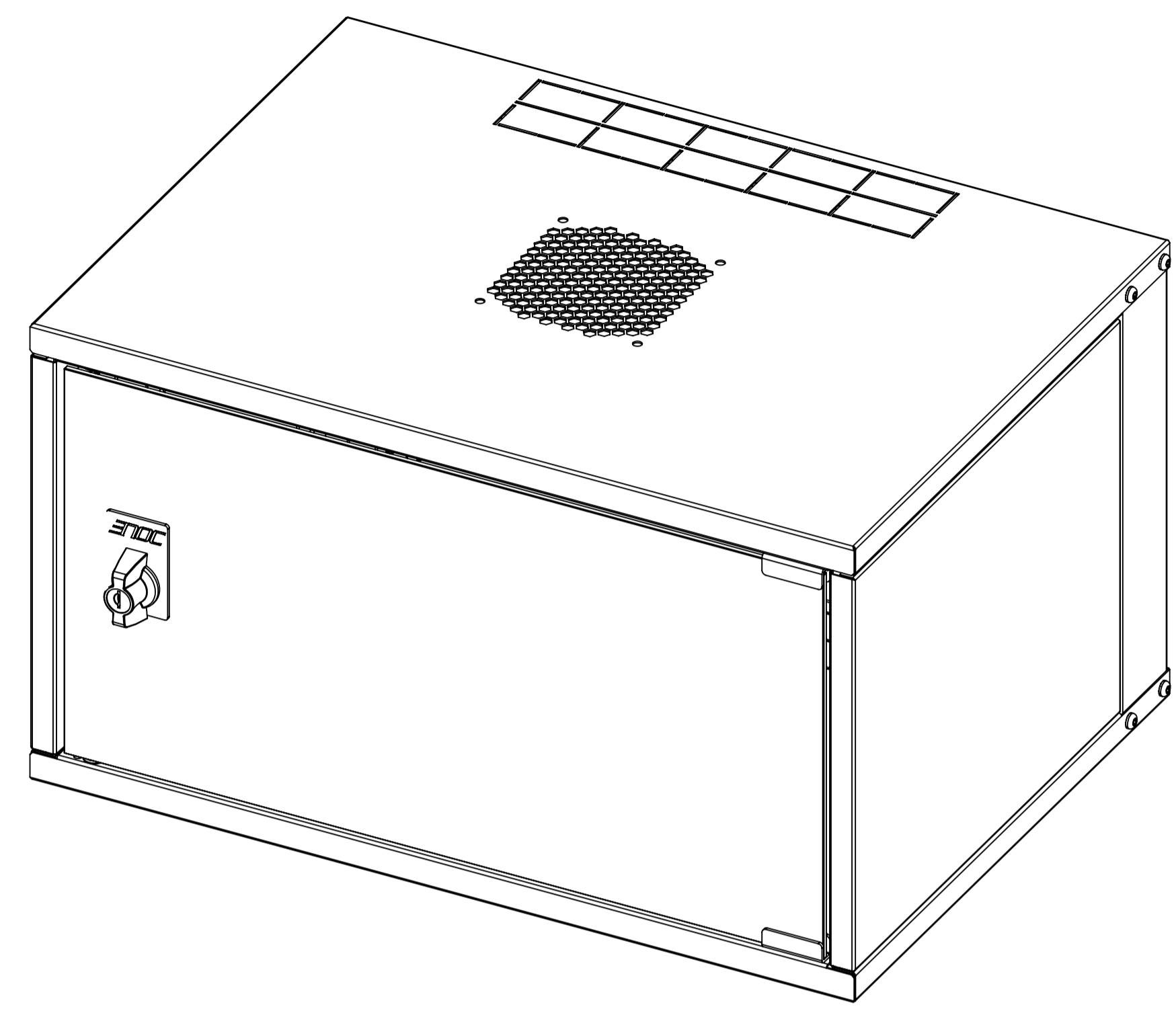

| Item no | Quantity | Description | Material |
|---------|----------|-------------------------------|----------|
| 12 | 4 | Screw RTK B10x9.5 - ACCESSORY | 4066-1 |
| 11 | 1 | BS 6 - ACCESSORY | 3831-1 |
| 10 | 28 | Screw RTK B10x9.5 | 4066-1 |
| 9 | 2 | SP Guide ENS | 4018-2 |
| 8 | 1 pair | Hinge for glassdoor | 3354-0 |
| 7 | 1 | LS 13 | 2936-0 |
| 6 | 1 | Coverplate standard lock | 0216-4 |
| 5 | 1 | GD 6 DSE/W3 | 2914-4 |
| 4 | 2 | Sidepanel 6-4 W3 | 3817-3 |
| 3 | 2 | PR 6 W3 | 3823-4 |
| 2 | 2 | Backpost 6 W3 | 3813-3 |
| 1 | 2 | Roof/Bottom 4 W3 | 3811-3 |

| Item no | Quantity | Description | Drawing no / Other |
|---|----------|------------------|----------------------------------|
| <small> För ej toleranssatta mått gäller toleranser enligt SS-ISO 2768-1 Gov. Dill sveitsar förkortas till sveitsbeteckningar enligt SS-ISO 2553. Vid sveitsning får ej sveitsstänk förekomma på färdig detalj. For dimensions without tolerances, tolerances according to SS-ISO 2768-1 Gov are valid. Where welds occurs are weld dimensions according to SS-ISO 2553. No weldspatter on finished detail. </small> | | | |
| Volym / Volume | | Konstr / Design | Datum / Date |
| Dimension | | Ritad / Drawn | Material |
| Skala / Scale | | Benämning / Name | Ytbehandling / Surface treatment |
| Rit-nr / Drawing no | | Utgåva | |

3D cad model: 3800-3



W3 6-4

141120-PA
3800-2-PA
1:5 / 1:3
3800 3

Denna handling är Electro Enocs egendom och får inte utan Electro Enocs skriftliga medgivande kopieras, delges tredje man eller användas för annat obehörigt ändamål. This document is the property of Electro Enoc and may not be copied, disseminated to third person or used for any other unauthorized purpose.

Copyright Enoc System AB